

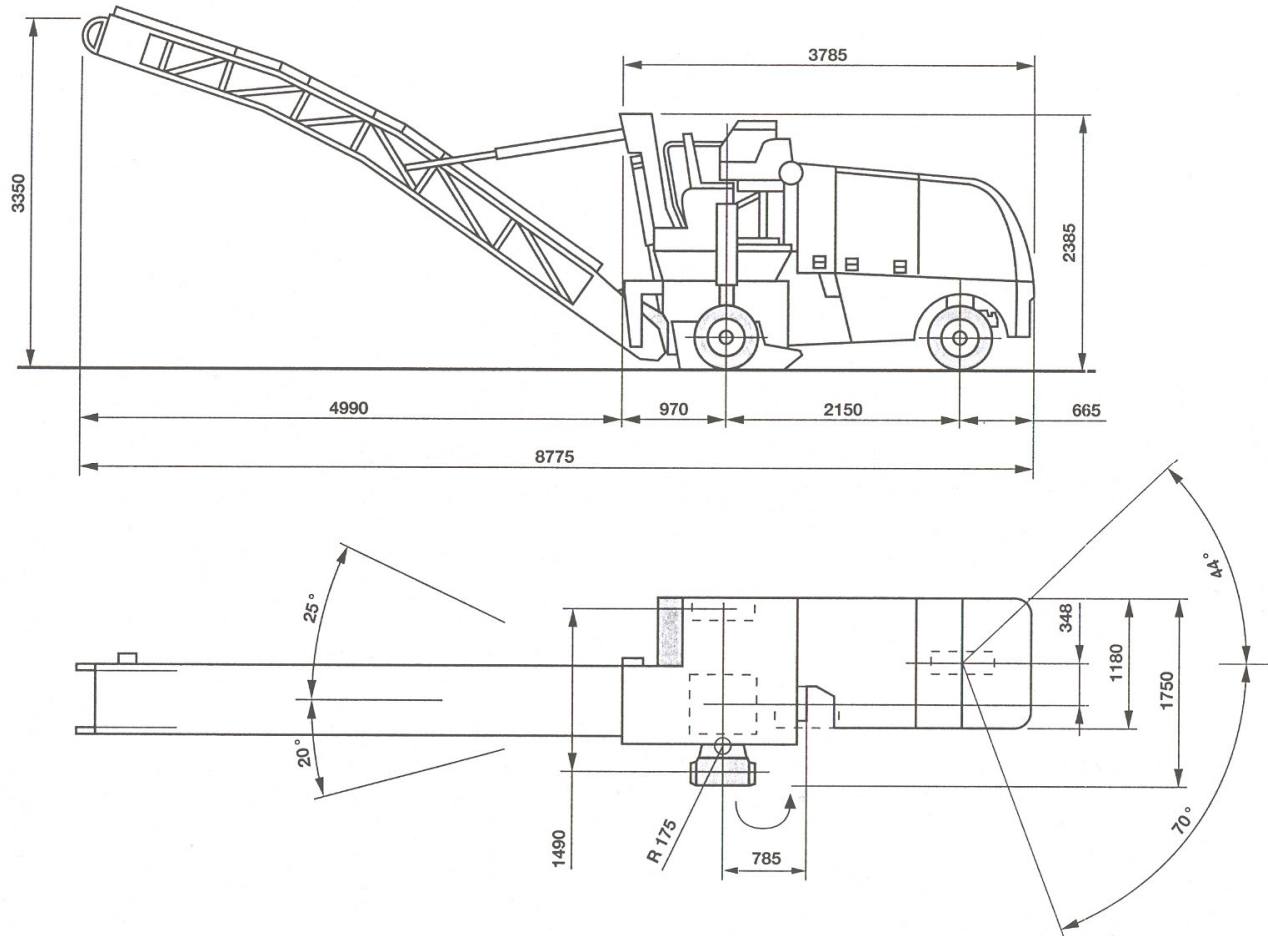

KALTFRÄSE W 50 DC

Masse in mm



Technische Daten		W 50 DC mit Ladeband	W 50 DC ohne Ladeband
Fräsbreite	mm	500	500
Frästiefe	mm	0 - 210	0 - 210
Füllmengen			
Kraftstofftank	l	230	
Hydrauliköltank	l	80	
Wassertank	l	600	
Gewichte			
Achslast vorne, vollgetankt	kg	2'860	3'530
Achslast hinten, vollgetankt	kg	5'140	3'820
Eigengewicht	kg	7'200	6'550
Betriebsgewicht, vollgetankt	kg	8'000	7'350